

**B.Sc. Semester-VI
Group-A / DSE-4
Organic Synthesis**



**III. Photochemistry
10. Photochemical Cycloaddition Reaction**



**Dr. Rajeev Ranjan
University Department of Chemistry
Dr. Shyama Prasad Mukherjee University, Ranchi**

**Photochemical cycloaddition reaction
(enone olefin cycloaddition)**

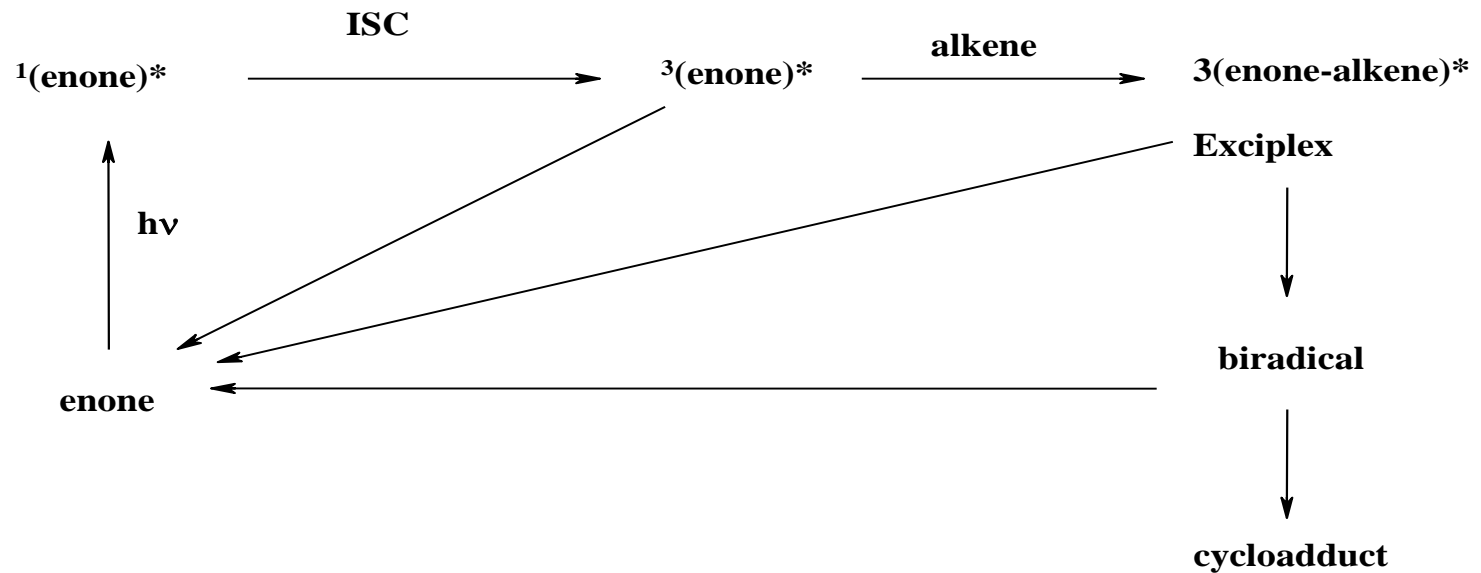
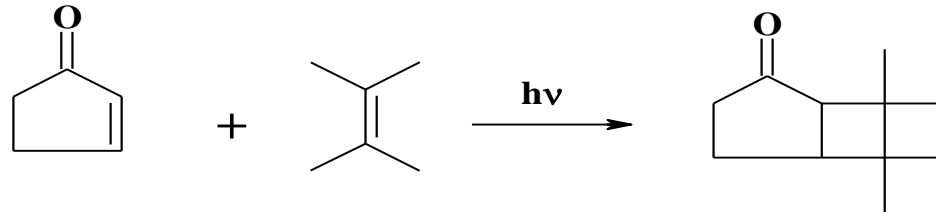

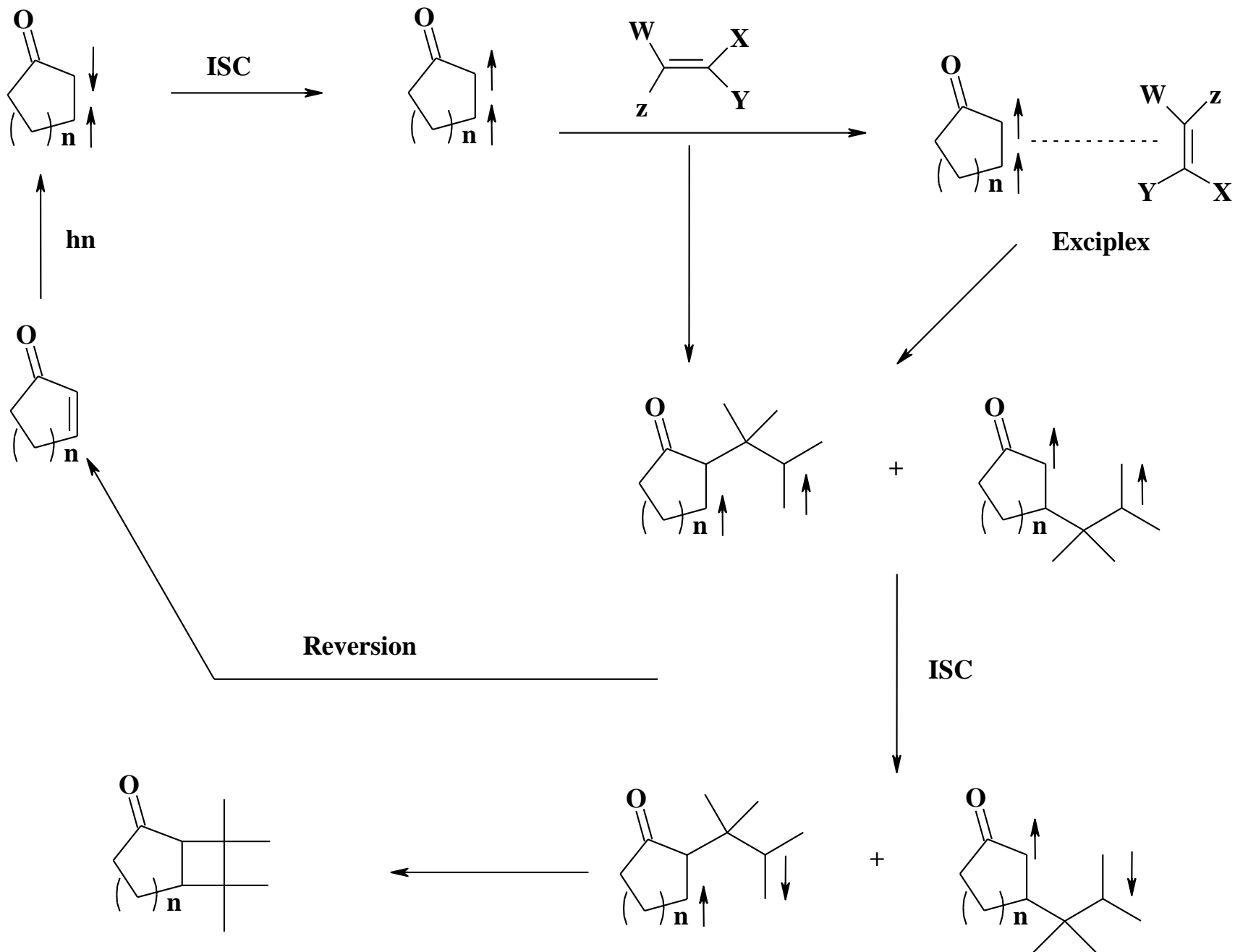

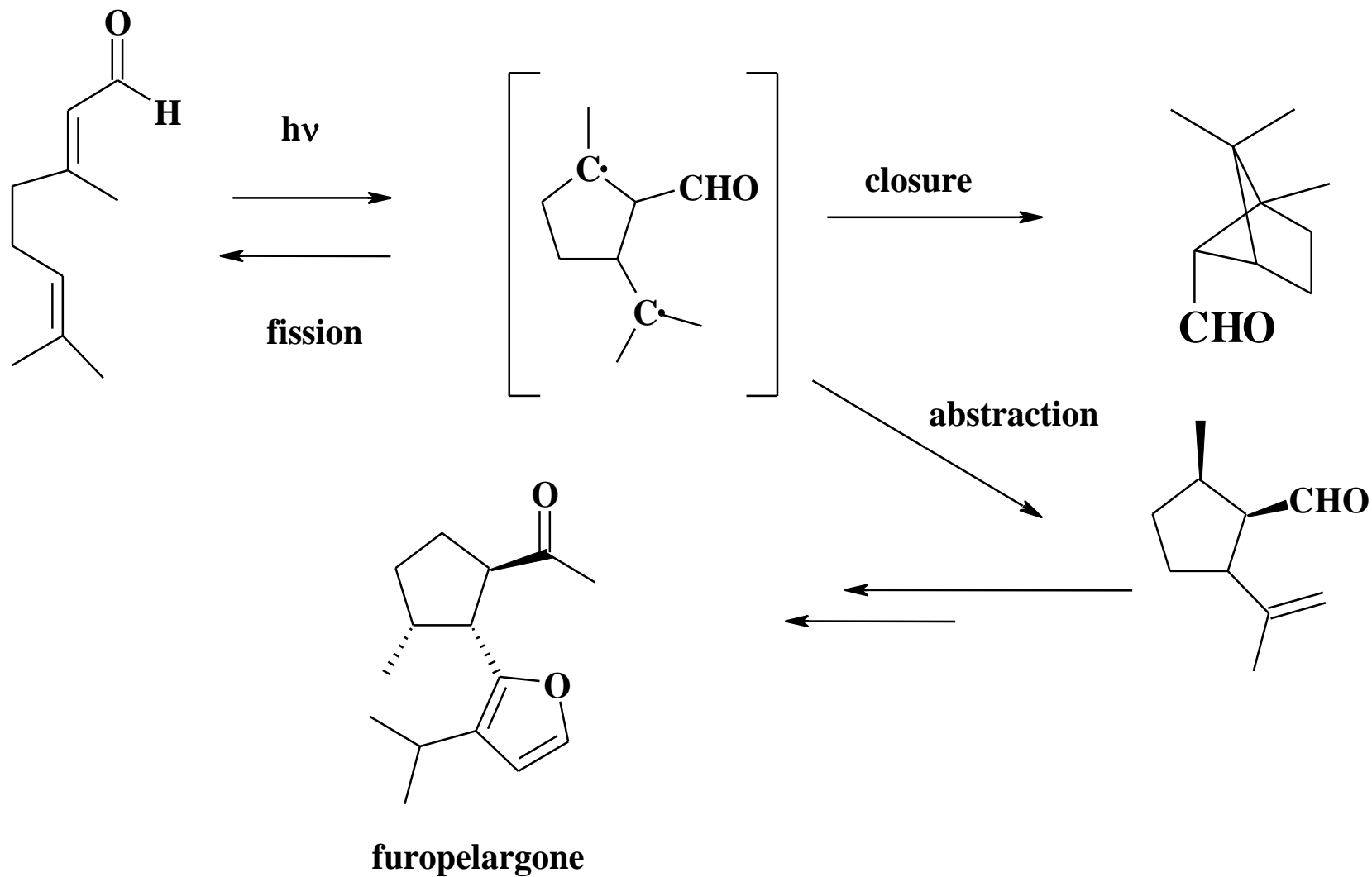

Regiochemistry of enone cycloaddition

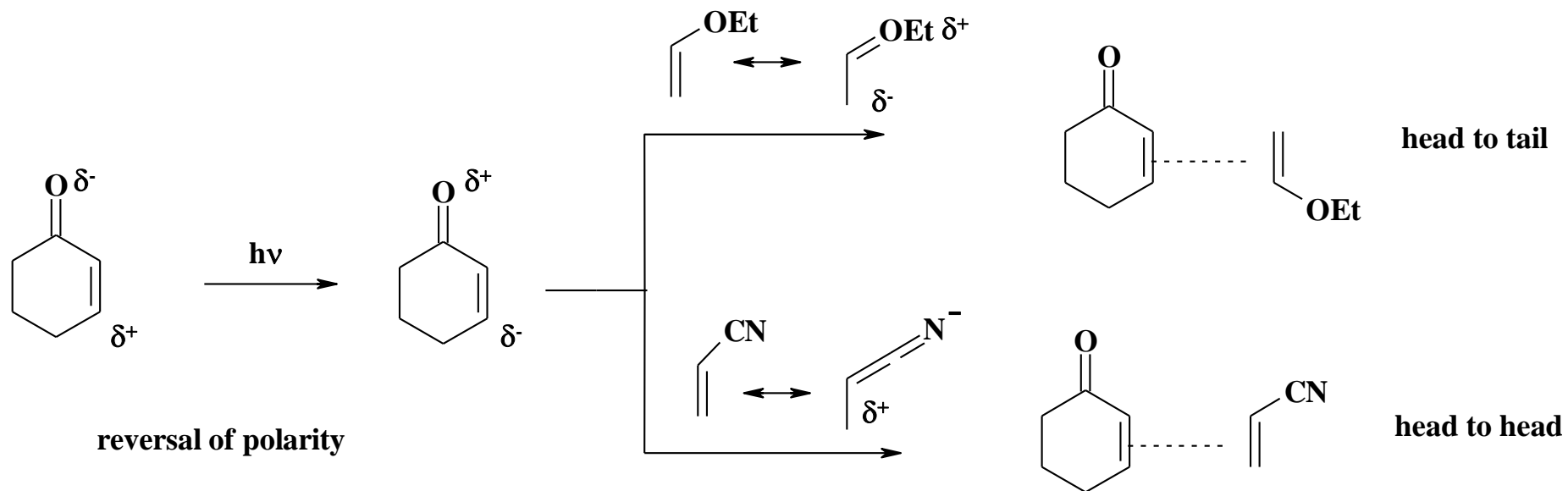
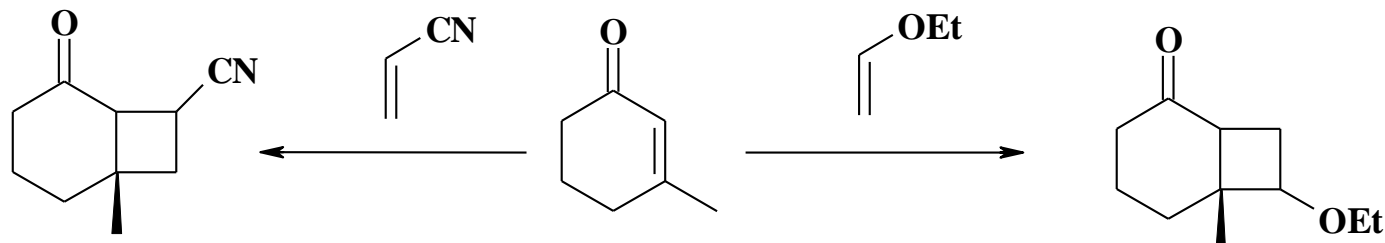

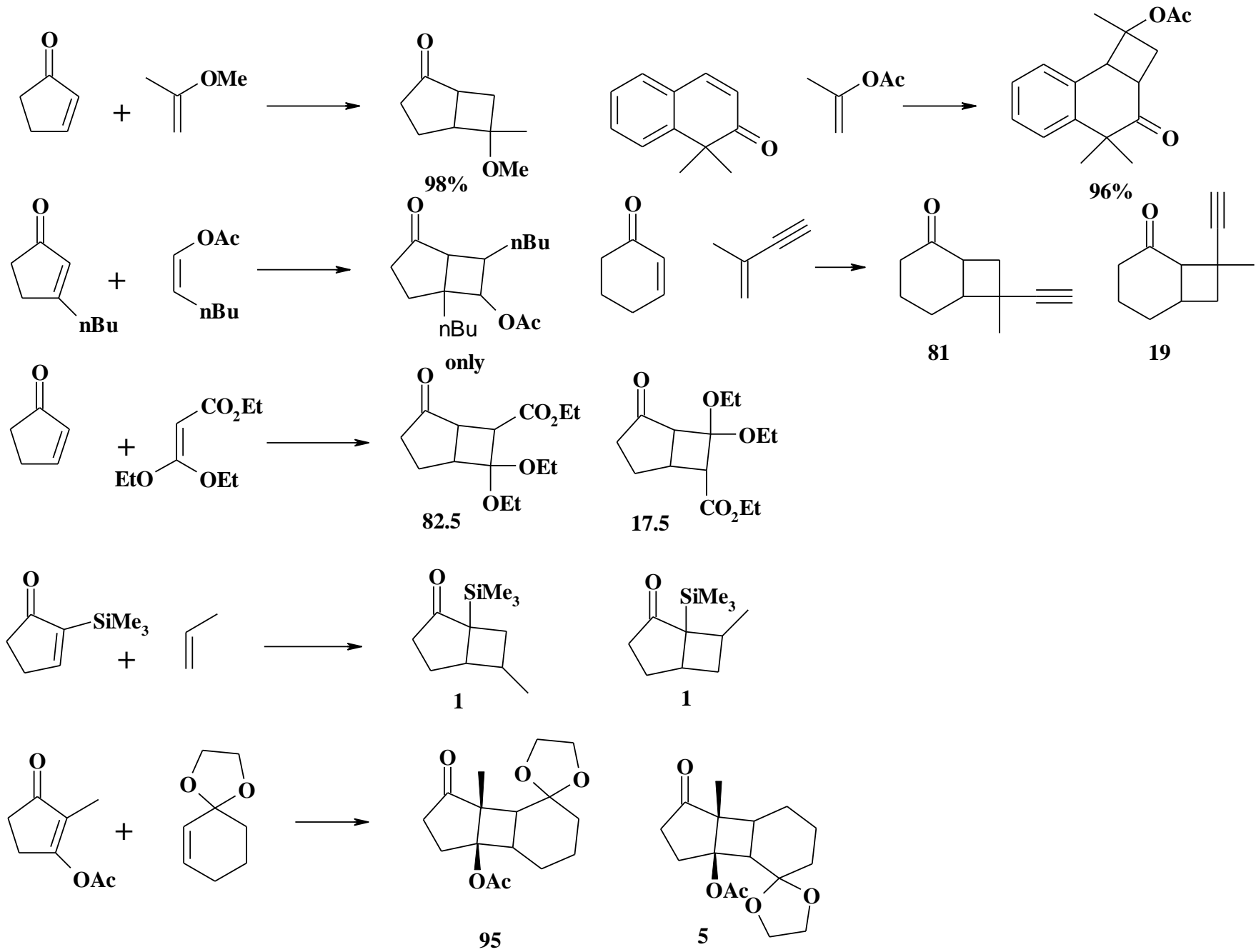

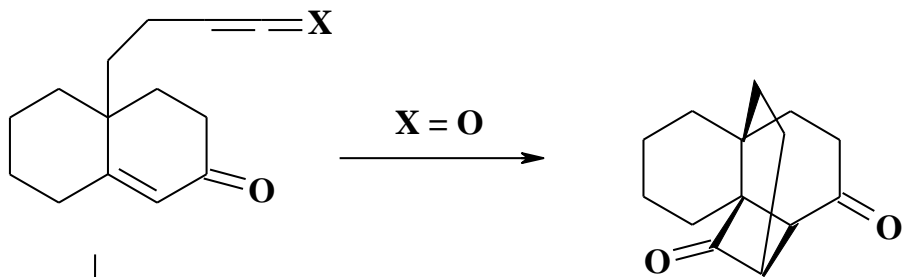

head to tail

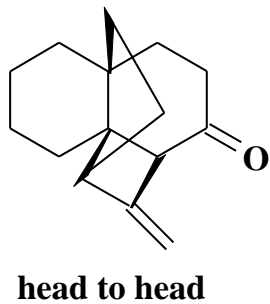

head to head

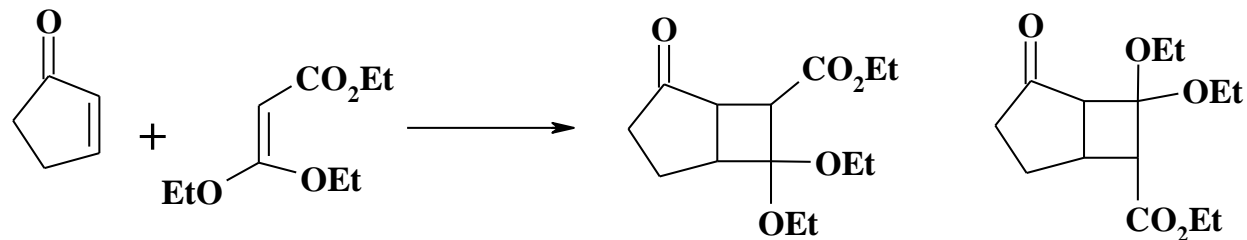

RT
-40°C

82.5
94

17.5
6

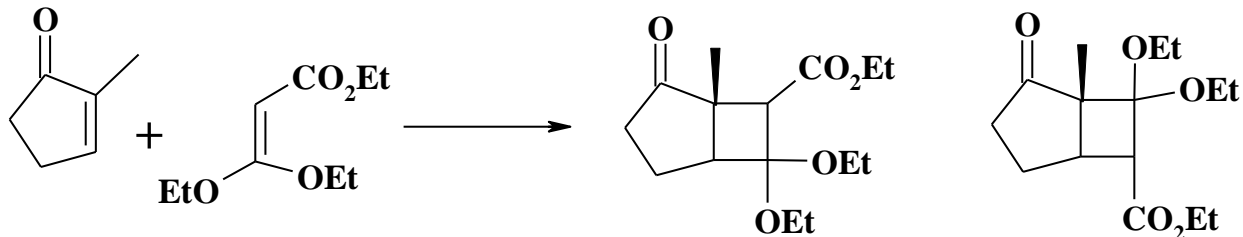

RT
-40°C

83.5
91.5

16.5
8.5

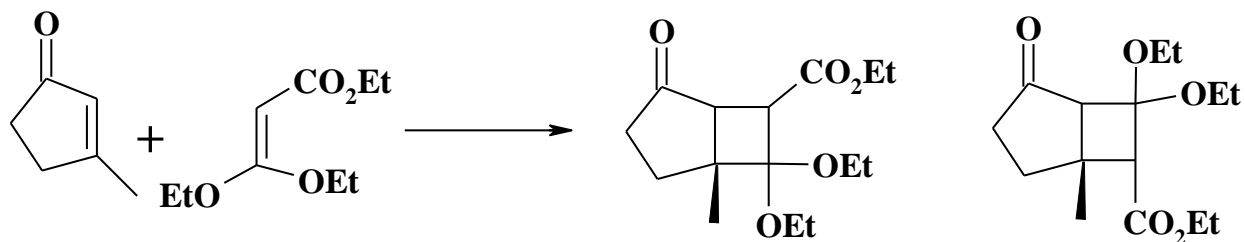

RT
-40°C

71
100

29
0

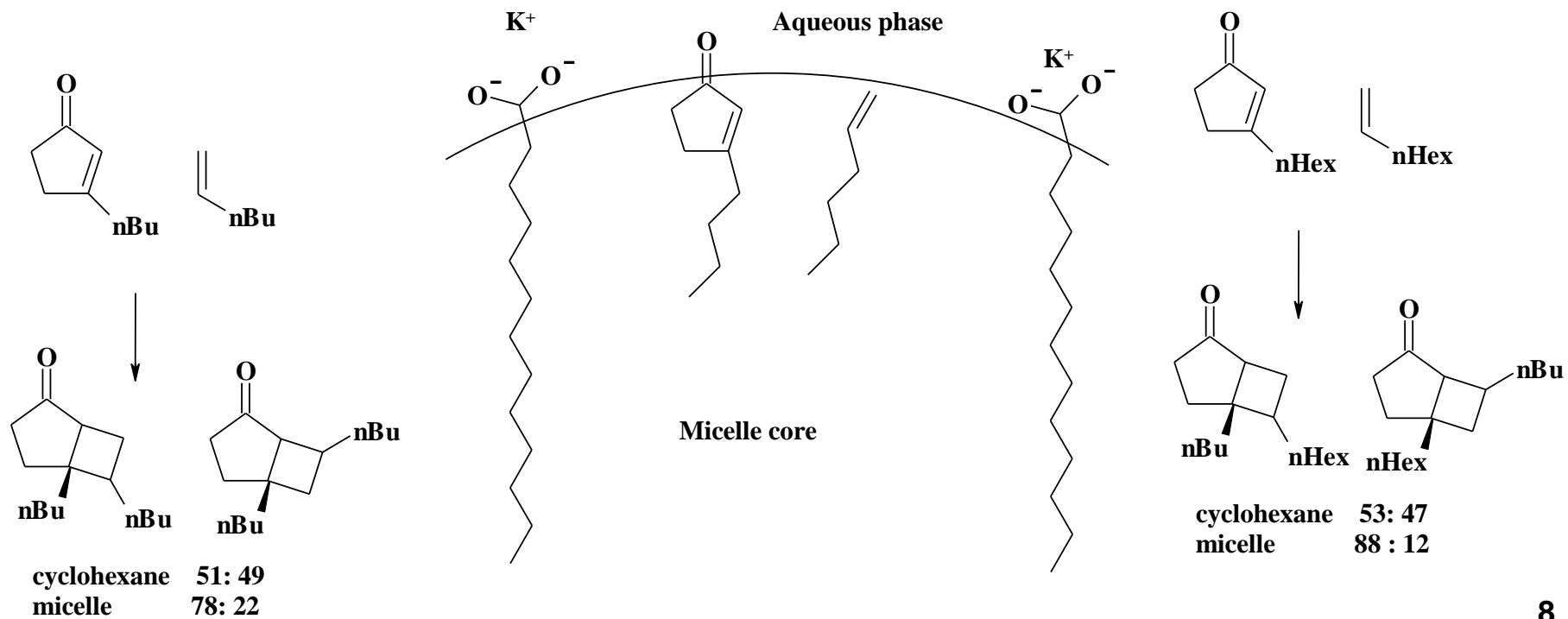
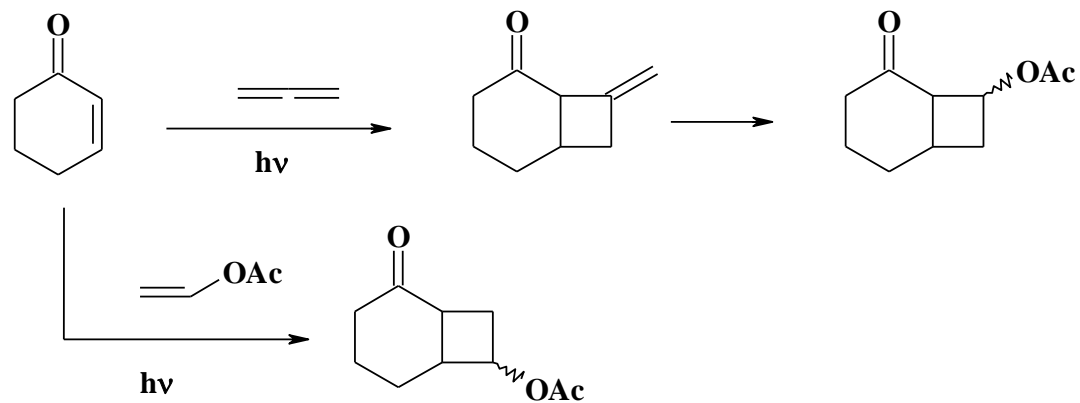

Stereochemistry of enone cycloaddition

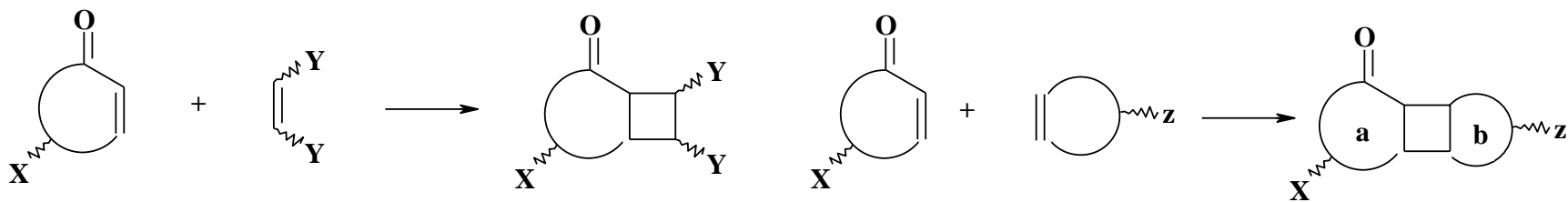

1. ring junction stereochemistry
2. exo or endo (Y)
3. cis or trans with respect to each other (y)
4. effect of remote substituents X

1. ring fusion stereochemistry
2. stereochemistry of a wrt b or vice versa
3. Remote substituents effect (X and Z)

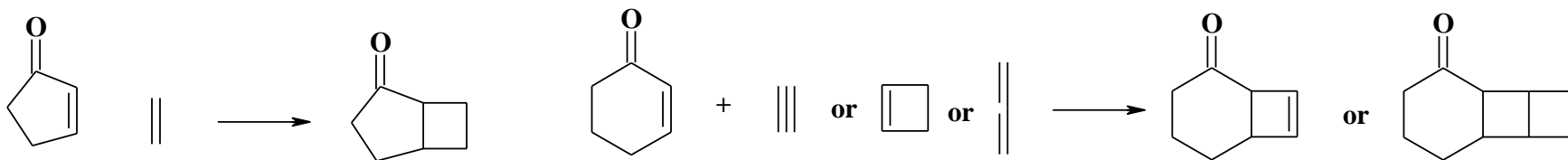

always cis ring fusion

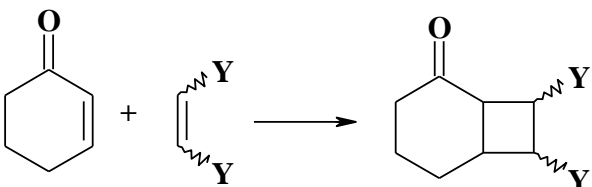

can be cis or trans
cis is favored

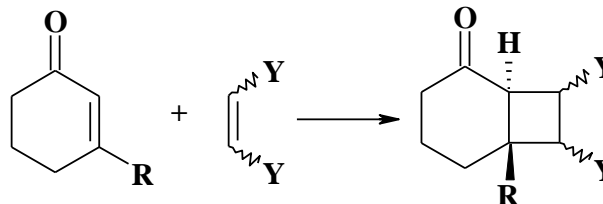

rigid cyclohexenones
(presence of heteroatoms,
fused ring)

always cis ring fusion

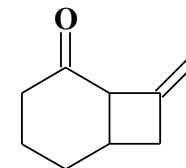

always cis fused ring junction

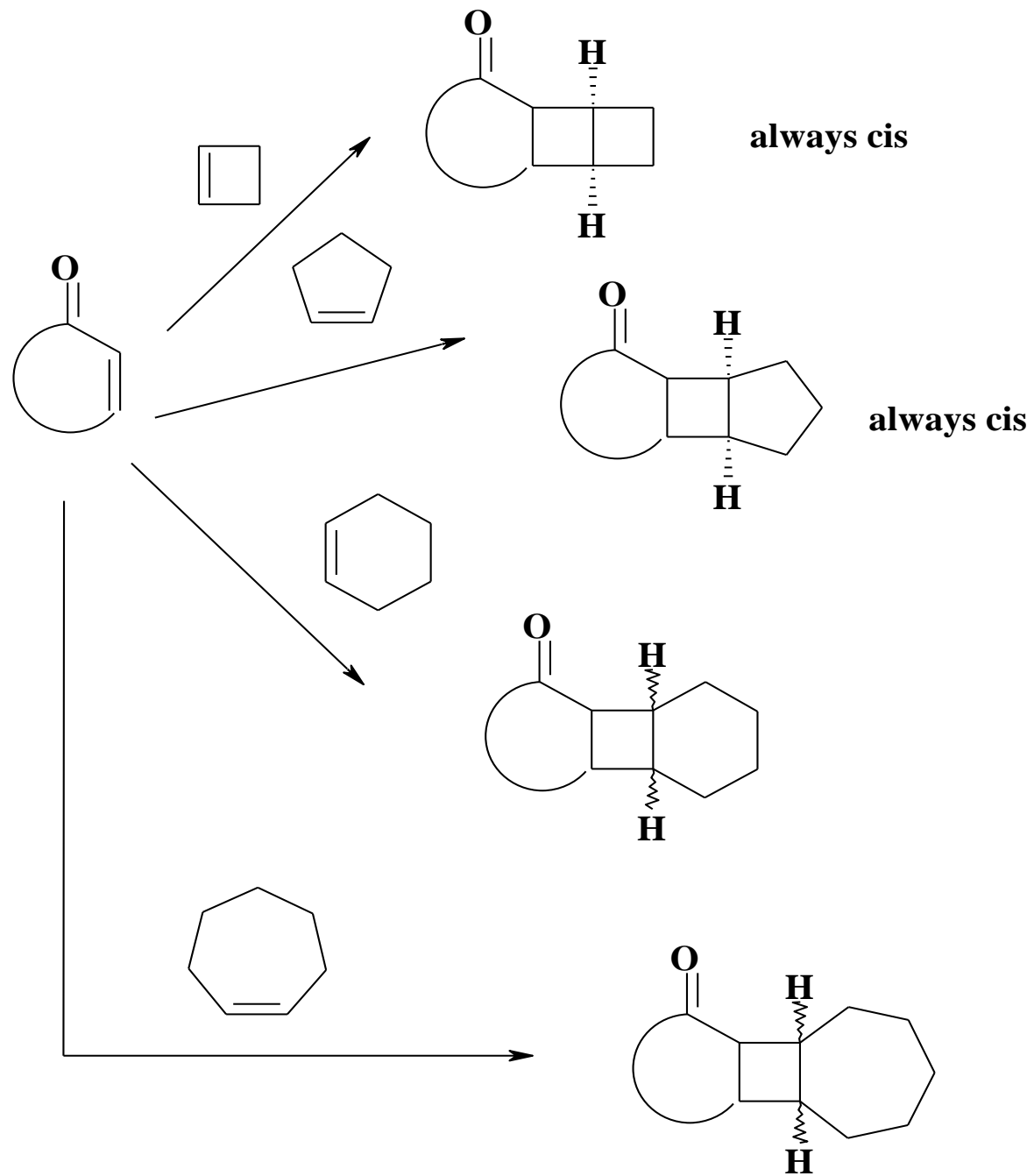

Regiochemistry of the intramolecular [2+2] photocycloaddition of 1,4; 1,5 and 1,6 dienes "Rule of FIVE"

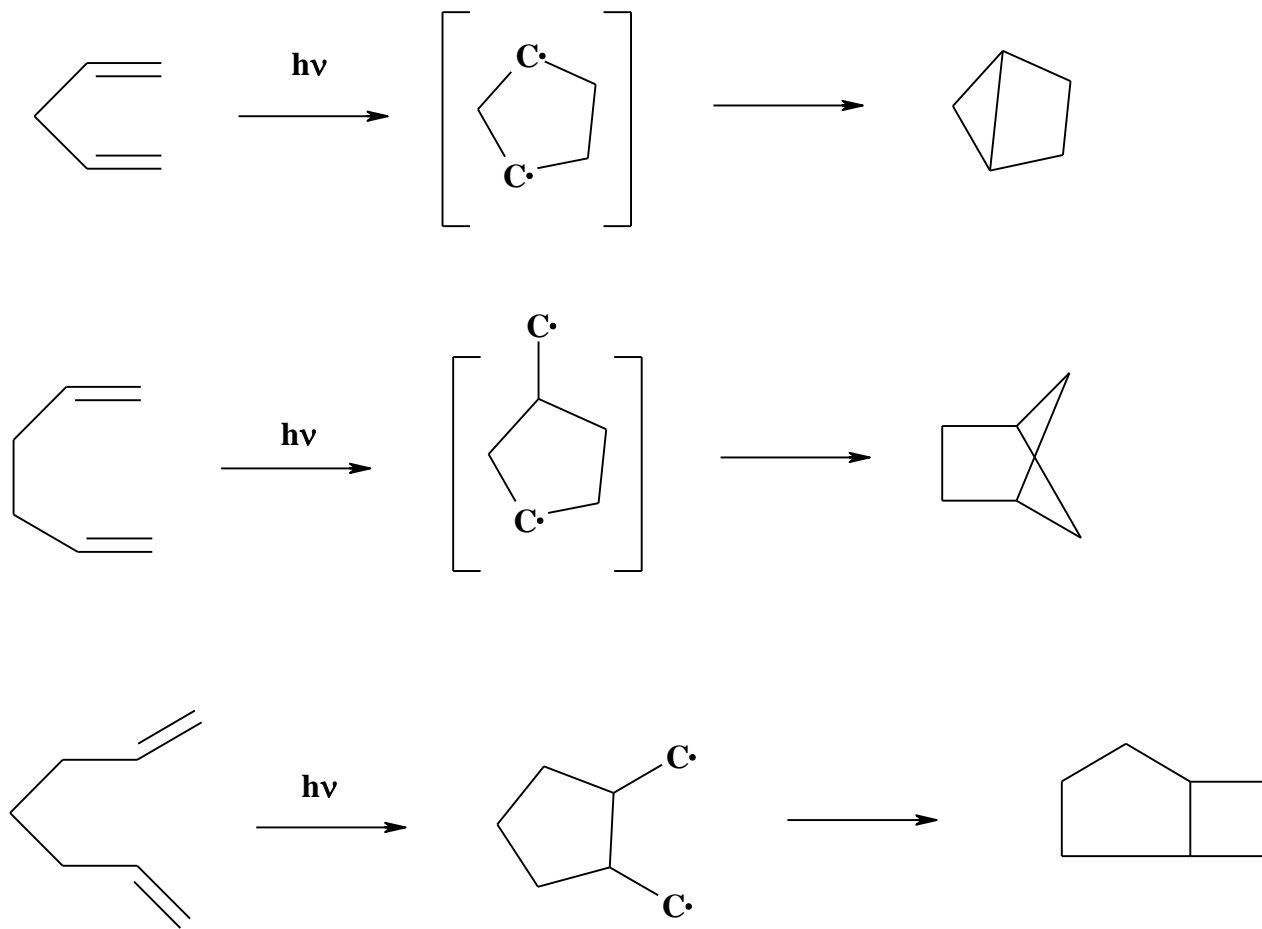

Intramolecular enone cycloadditions

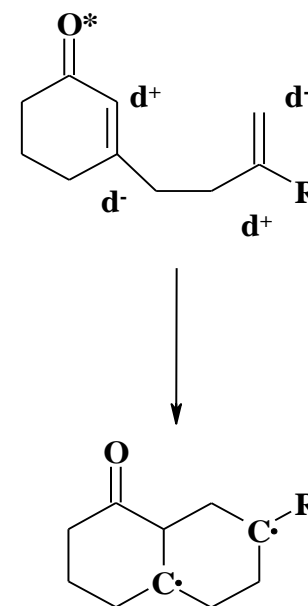
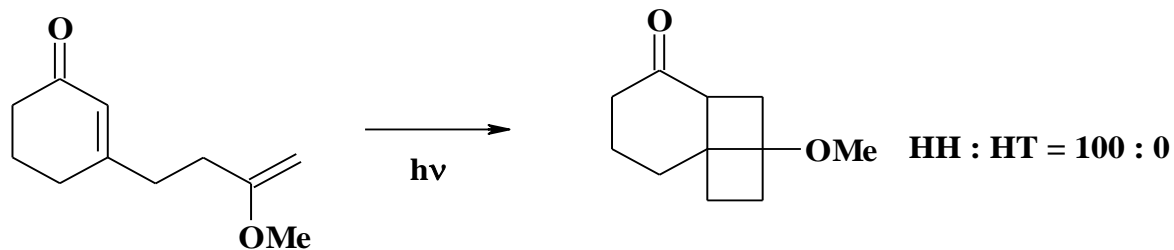
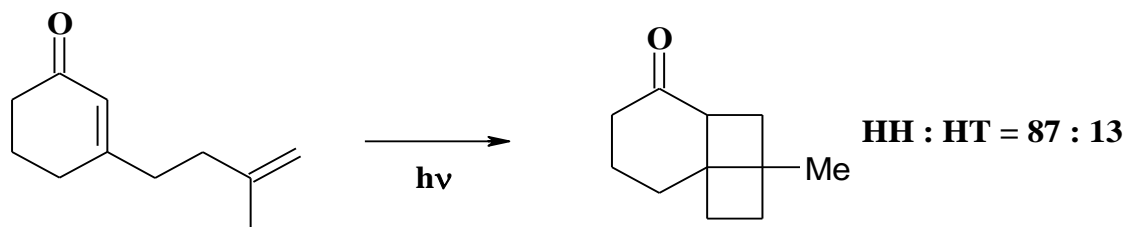
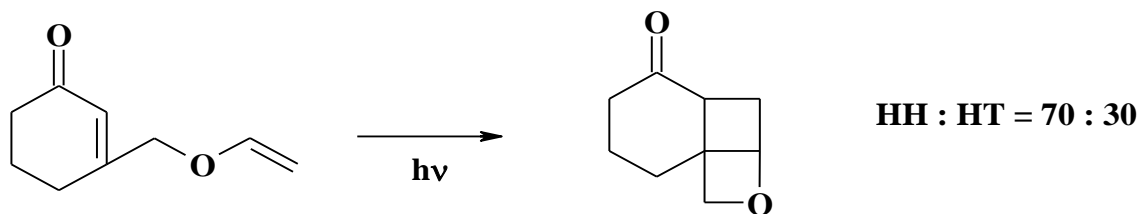
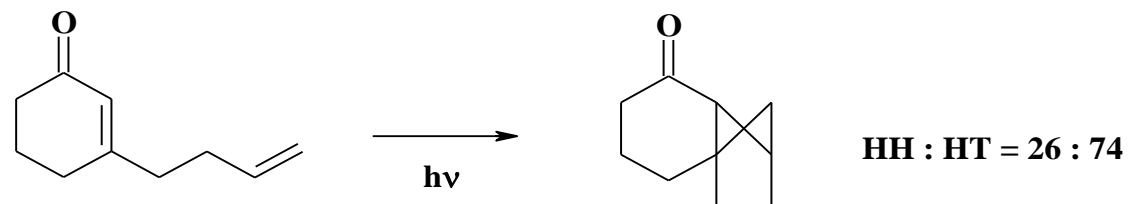
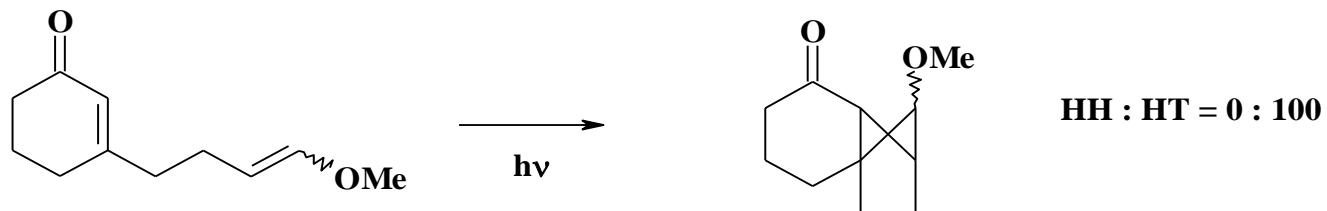

enone cycloadditions in organic synthesis

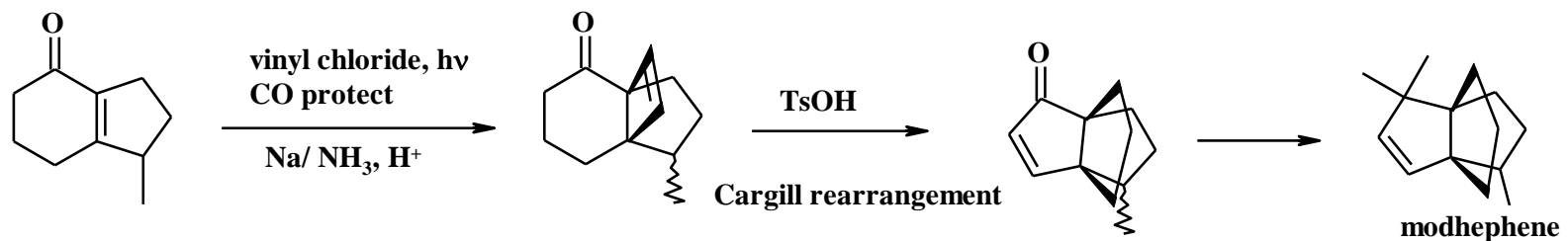
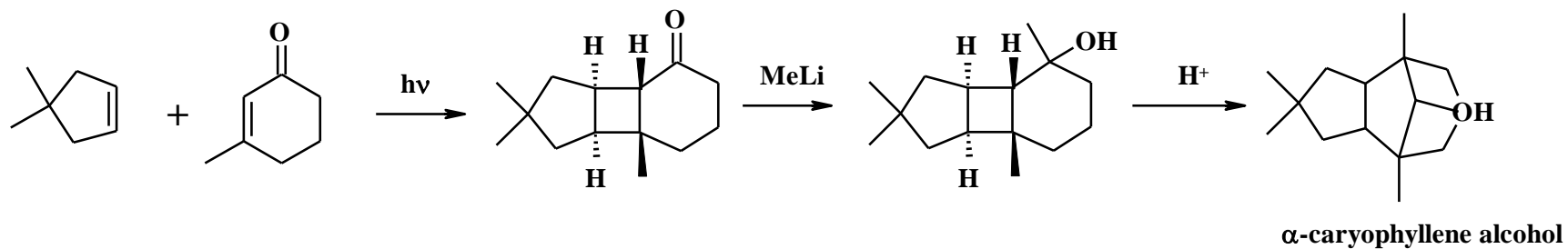
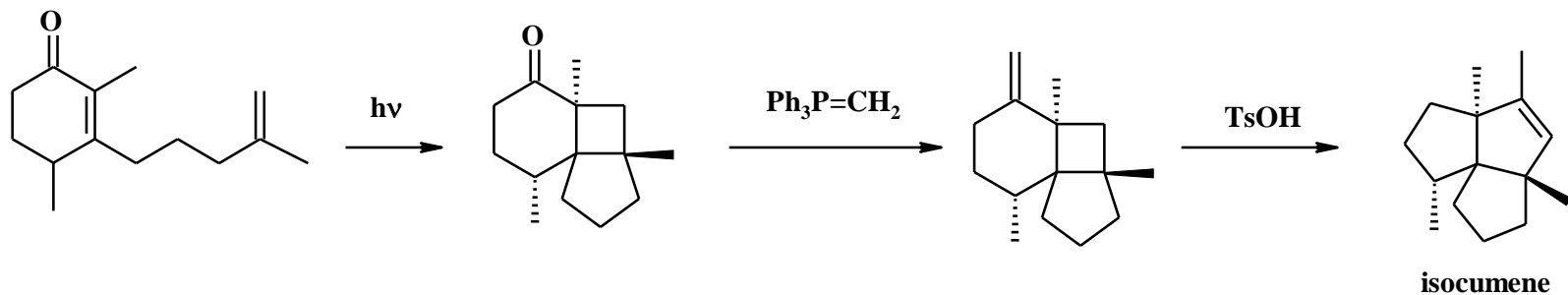
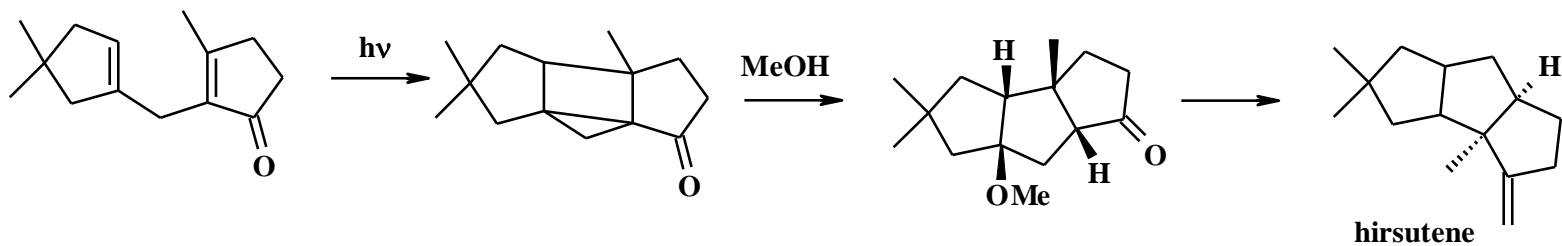

Thank You



Dr. Rajeev Ranjan
University Department of Chemistry
Dr. Shyama Prasad Mukherjee University, Ranchi